

%zk1.nc "TURN_V1.0"

HEADER [Hlavicka Progr.]

#MATERIAL Stahl [MATERIAL]
#MEASURE_UNITS METRIC [JEDNOTKA]

TURRET 1 [Revolver]

T1 ID"A-SCHR-35-08"
T2 ID"A-SCHL-35-04"

CLAMPS [Upínač]

CLAMPS 2 [Upínač]

BLANK [Polotovár]

N 1 G20 X50 Z102 K2

FINISHED [Hotový obrobek]

N 2 G0 X0 Z0
N 3 G1 X20 BR-5
N 4 G1 Z-30 BR30
N 5 G1 X50 Z-50
N 6 G1 Z-100
N 7 G1 X0

MACHINING [Obrábění]

N 10 G140 D1 X300 Z100
N 22 G14 D1 T1
N 18 G47 P2 G26 S3000
N 19 G96 S200
N 20 G95 F0.2 M4

N 11 G820 NS3 NE3 P2 K0.2 V3
N 8 G810 NS4 NE5 P10 IO.3 K0.1

N 22 G14 D1 T2
N 25 G96 S250 G95 F0.1
N 17 G890 NS3 NE3 V3 H3
N 23 G890 NS4 NE5 H3
N 24 G14 D1

N9900 UNIT ID"END"

N9901 [<unit ID="END" ME="30" NS="" G14="-1" MFS="" MFE="" />]

N9902 M30

N9903 END_OF_UNIT

END

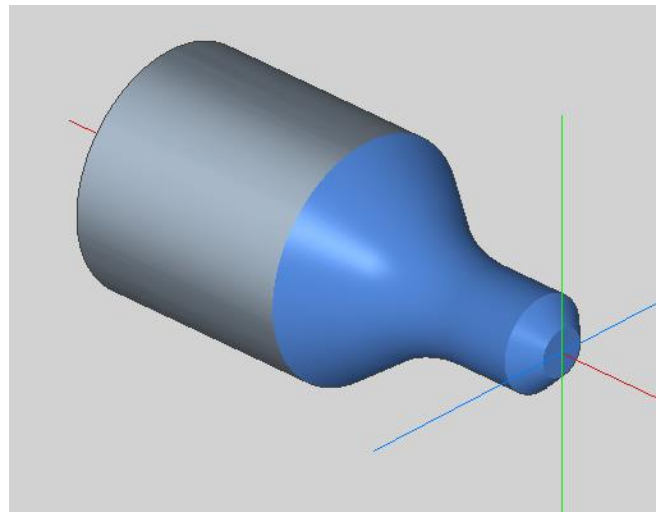

Definice místa výměny nástrojů D1

